

NWF2046-2

GYNECOLOGICAL EXAMINATION TABLE



NWF2046-2

FEATURES AND HIGHLIGHTS

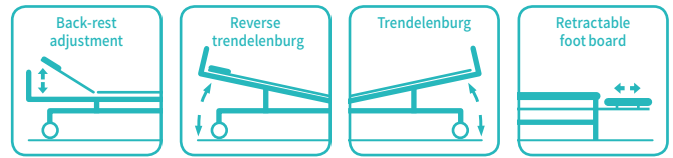

Technical parameters

Overall dimensions	1830×625×800mm
Back lifting	0-63° (±5°)
Trendelenburg	0-18° (±2°)
Reversed trendelenburg	0-18° (±2°)
Gross weight	47kg
Net weight	45kg
Packing size	710×300×1350mm

Technical configuration

<input checked="" type="checkbox"/> Mattress	1 set
<input checked="" type="checkbox"/> Guardrail	3 pcs
<input checked="" type="checkbox"/> Manual crank	1 pc
<input checked="" type="checkbox"/> Assist handle	2 pcs
<input checked="" type="checkbox"/> Legrest	2 pcs
<input checked="" type="checkbox"/> IV pole	1 pc
<input checked="" type="checkbox"/> Waste basin	1 pc



Design

Suitable for hospitals, clinics, family planning centers, and mobile gynecological vehicles. Auxiliary equipment for diagnostic surgery and family planning examination.



Material

High-quality stainless steel construction, with a thickness of 1.0 mm and strong load capacity (up to 150 kg).



Welding

Argon arc welding, neat and smooth seams.

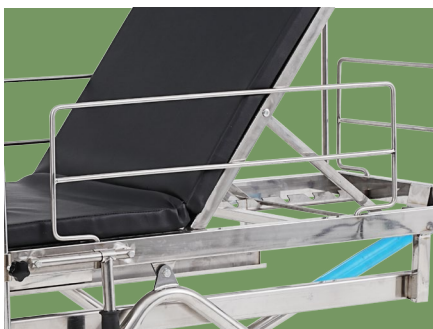

Guardrail

Three sides equipped with detachable stainless steel guardrails, making it easy for patients to get on and off the bed. The guardrail height is 250mm±10mm.



Back Plate

Backrest controlled by a gear rack, can be adjusted to raise at an angle of 0-63.5°±5°, facilitating patient sitting.

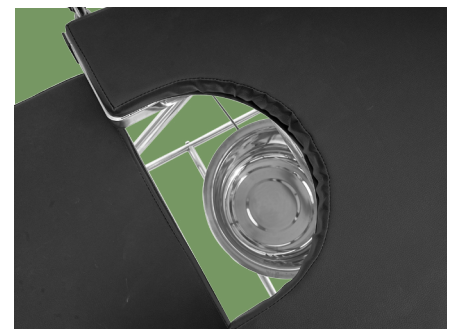

Seat Plate

U-shaped cutout for easy doctor access.



Leg Plate

Foldable sliding leg board has a knob limit design for effortless sliding and compact storage.

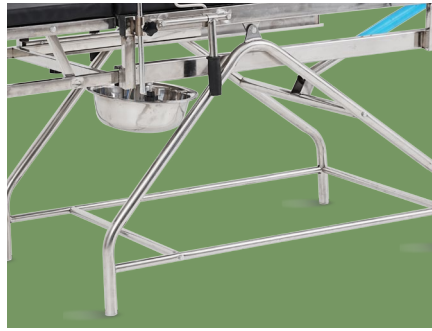

Base

Stable triangular base design facilitates adjusting the bed's horizontal tilt angles for various positions.



Lever

Lever is made of steel, offering high support strength, durability, safety, and noiseless operation for smooth usage.



Mattress

High-density sponge mattress with PU cover and a U-shaped cutout at the hip area for doctor convenience. The mattress thickness is 40mm.



Assist handle

Foldable assist handles, easy for patients to grip.



Legrest

Manual multi-angle adjustment for added convenience.



IV pole

Stainless steel IV pole with four hooks, convenient for patient infusion.



Waste basin

Standard stainless steel waste basin (30cm in diameter), sturdy, easy to install, detachable and position adjustable.





NUMBER WIN

MEDICAL TECHNOLOGY

As the circumstance of printing, the photos might have minor difference on color, tactile from real products.
As the update of design and improvement, parameters and outlook of products might change, thanks for understanding.



7x24

Online 24 Hours for Sales Service
Timely Response for Clients' Problems

+86 18021231901

Suzhou Number Win Medical Technology Co.,Ltd.

No. 35, Lehong Road · Zhangjiagang (Jiangsu) · China

export@number-win.com

www.number-win.com



Company video



General catalogue